

Tüp Motor Teknik Katalođu
Tubular Motor Technical Catalogue



HAKKIMIZDA

Çalışma hayatına 1984 yılında başlayan Akseki Yapı, kuruluşunu tamamladığı 1999 yılından bu yana ticari faaliyetlerine devam etmektedir. Ürün yelpazesini her geçen gün geliştiren ve çeşitlendiren şirket, üretim kapasitesi ve tedarik zinciri ile alanında, Türkiye'nin öncü firmaları arasında yer almaktadır. Uluslararası piyasada da sürdürdüğü ihracat ağı sayesinde sektördeki yerini sağlamlaştırmaktadır.

Toplam 100.000 m2'lik alanda 300'ü aşkın çalışanıyla üretime hız kesmeden devam eden Akseki Yapı, kendi panjur ve kepenk markası olan Whiteform, tubular motor markaları olan Aksimo ve

Whiteplus ile alüminyum sistemleri ürettiği Rigel markasıyla profesyonel ve yenilikçi üretim anlayışını sürdürmektedir. Akseki Yapı kuruluşundan bu yana üretim ve uygulama kriterlerini, uluslararası kalite standartlarını baz alarak belirlemiştir. Sektörünün ve iş ortaklarının gereksinimlerini sürekli olarak izleyen ve analiz eden şirket, bu tavrı ile sektöründeki yerini korumaya devam etmektedir.

Kaliteli ve uzun ömürlü ürünleri ile güvenilir markalar yaratan şirket, tüm üretim ve uygulama hatlarında yüksek kalite standartlarını korumaya devam etmektedir.

ABOUT

Akseki Yapı, which started in 1984, has been continuing its commercial activities since 1999 when it was founded. Developing and diversifying its product range day by day, the company is among the leading companies of Turkey in its field by its production capacity and supply chain. However, by the export network that maintains in the international market, and strengthens its position in the sector.

Continuing its production without slowing down with its more than 300 employees in a total area of 100,000 m2, Akseki Yapı maintains its professional and innovative production approach with its own roller shutter and shutter brand WhiteForm, tubular motor brands Aksimo and Whiteplus, and aluminum systems under the Rigel brand.

Akseki Yapı has determined its production and application criteria based on international quality standards since its establishment. Akseki Yapı constantly monitors and analyzes the needs of its sector and business partners, continues to maintain its position in the sector with this attitude.

Akseki Yapı which creates reliable brands with its quality and long-lasting products continues to maintain high quality standards in all production and application lines.

I Goals and Principles

Akseki Yapı, kurulduğu günden bugüne kadar her zaman personeliyle birlikte tüm alanlarda adil olmayı amaçlamıştır. Müşterilerinden, bayilerine, rakiplerinden, toplumun her bir bireyine kadar adil, hakkaniyetli, saygın ve devamlılık esaslı hizmet sunmayı hedef edinmiştir.

Kalite, standart, güvenilirlik...

Akseki Yapı'nın çalışanlarından başlayıp bayilerine kadar devam eden kurumsal anlayışının en temeli; ürün ve hizmetlerinin kalitesini standartların üzerinde tutmak ve markalarının güvenilirliğini her daim korumaktır.

Saygılığımız ana sermayemizdir...

Saygılığı her şeyin üstünde tutan Akseki Yapı, sektörde ilk tercih edilen firma olmayı, müşteri memnuniyeti sağlamayı; insana, doğaya ve çevreye saygılı olmayı ana ilkeleri olarak belirlemiştir.

Akseki Construction, has always meant to be just in all areas together with its personnel since its establishment. It has aimed to provide just, fair, reliable and sustainability based services for each and every individual of the society from its customers and vendors to rivals.

Quality, standard, reliability...

The basis of the corporate insight of Akseki Construction that begins from its employees and continues to its vendors is to keep the quality of its products and services beyond the standards and forever maintain the reliability of its brands.

Our reputation is our major capital...

Valuing reputation above everything else, Akseki Construction determined its main principles as being the most preferred firm in the industry, fulfilling customer satisfaction, and being respectful to mankind, nature and environment.

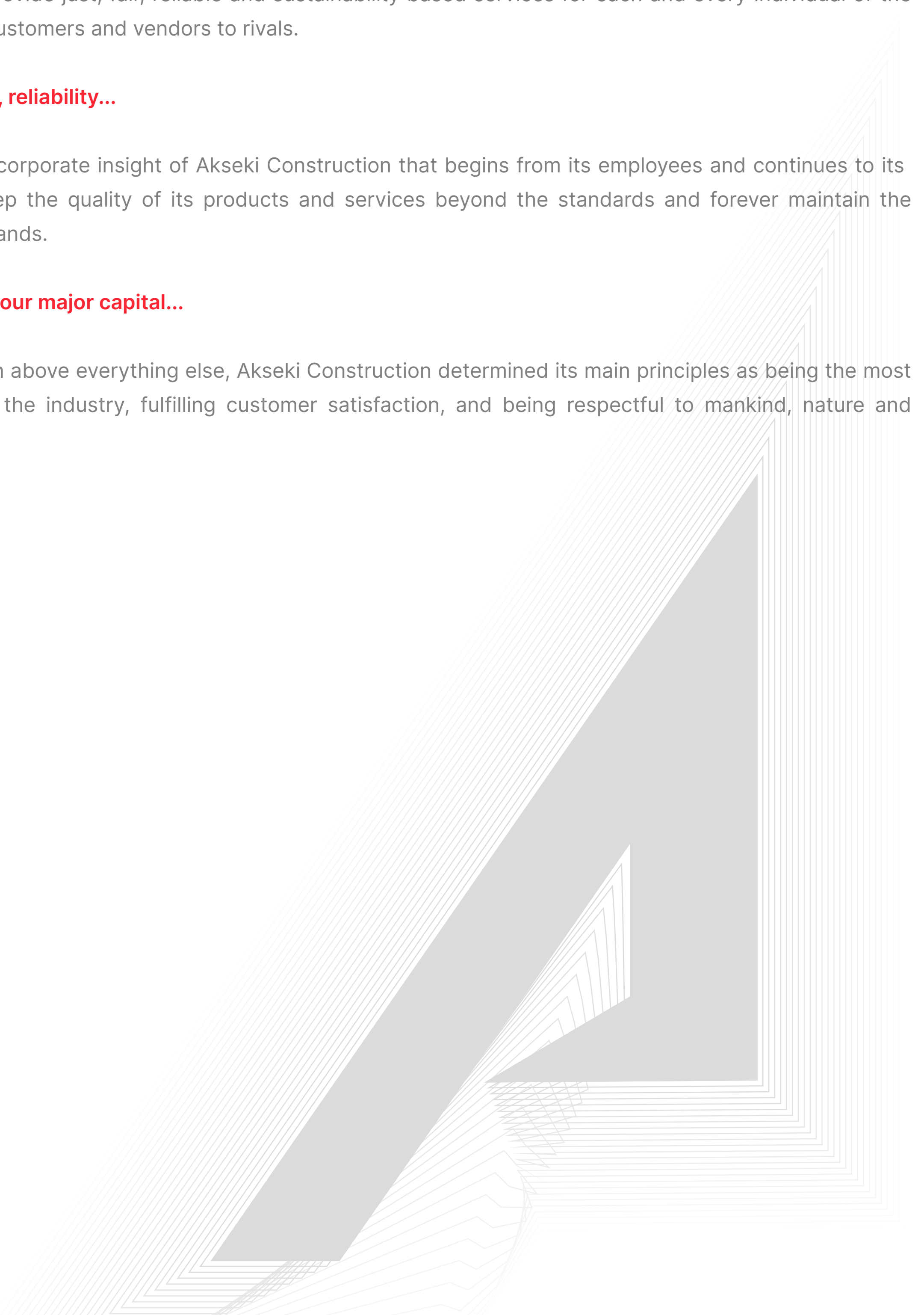

Aksimo
Professional Solutions

AKSEKI[®]

Tüm Türkiye'de Yaygın Müşteri Portföyü Widespreaded Customer Scale in All Turkey





GÜVENİLİR ADIMLARLA BÜYÜYORUZ

We Are Progressing By Trustworthy Steps

Tüm Türkiye'de **Yapı Sektörü'nün**
Öncü Firması

Leader Firm of Building Sector in Turkey

Türkiye'den Dünya'ya Açılan
Bir Türk Markası

A Turkish brand originated in Turkey to all over the world

AKSEKI®



ULUSLARARASI ARENADA BÜYÜK BİR
SATIŞ KAPASİTESİ

A HUGE SALES CAPACITY IN INTERNATIONAL MARKETS

Avrupa, Asya, Afrika ve Güney
Amerika Kıtalarına Sağladığı
İhracat Ağı ile Yüksek Hedefler

In the continents of EUROPE, ASIA, AFRICA and SOUTH
AMERICA; widespread export network provides the
highest targets.

AKSEKI®



26'dan Fazla Ülke

MORE THAN 26 COUNTRIES



AKSEKI®



HER GEÇEN GÜN DURMAKSIZIN BÜYÜYEN
SEKTÖREL GÜÇ

Sectorel Power! Increasing Day by Day Without Stop

300'den Fazla İstihdam

Employees More than 300

37 Yıllık Tecrübe

37 Years of Experience

AKSEKI®

Dünya'nın Panjur ve KepenK Alanında

TEDARİKÇİSİ

World Supplier of Rolling Shutter & Shutter

- **Montaja Hazır Pergola ve Zip Perde Üretim Hatları**
Ready-assembled Pergola and Zip Curtain Production Lines
- **Plastik Enjeksiyon Üretim Hatları**
Plastic Injection Production Lines
- **Lamel Üretim Hatları**
Slat Production Lines
- **Elektrostatik Toz Boyama ve Transfer Kaplama Hattı**
Electrostatic Powder Coating and Transfer Coating Line
- **Montaja Hazır Panjur Üretim Hatları**
Rolling Shutter Production Lines (as ready to being installed)
- **PVC Laminasyon Hattı**
PVC Lamination Line
- **Alüminyum Kutu Şekillendirme Hattı**
Aluminum Box Framing Line
- **Sekizgen Boru Hatları**
Octagonal Tube Lines
- **Kalite Kontrol Alanı**
Quality Control Area
- **Teknik Servis**
Technical Service
- **Stok ve Sevkiyat Alanları yer almaktadır.**
Stock and Transportation Area

A.O.S.B. - Çiğli / İzmir - TÜRKİYE

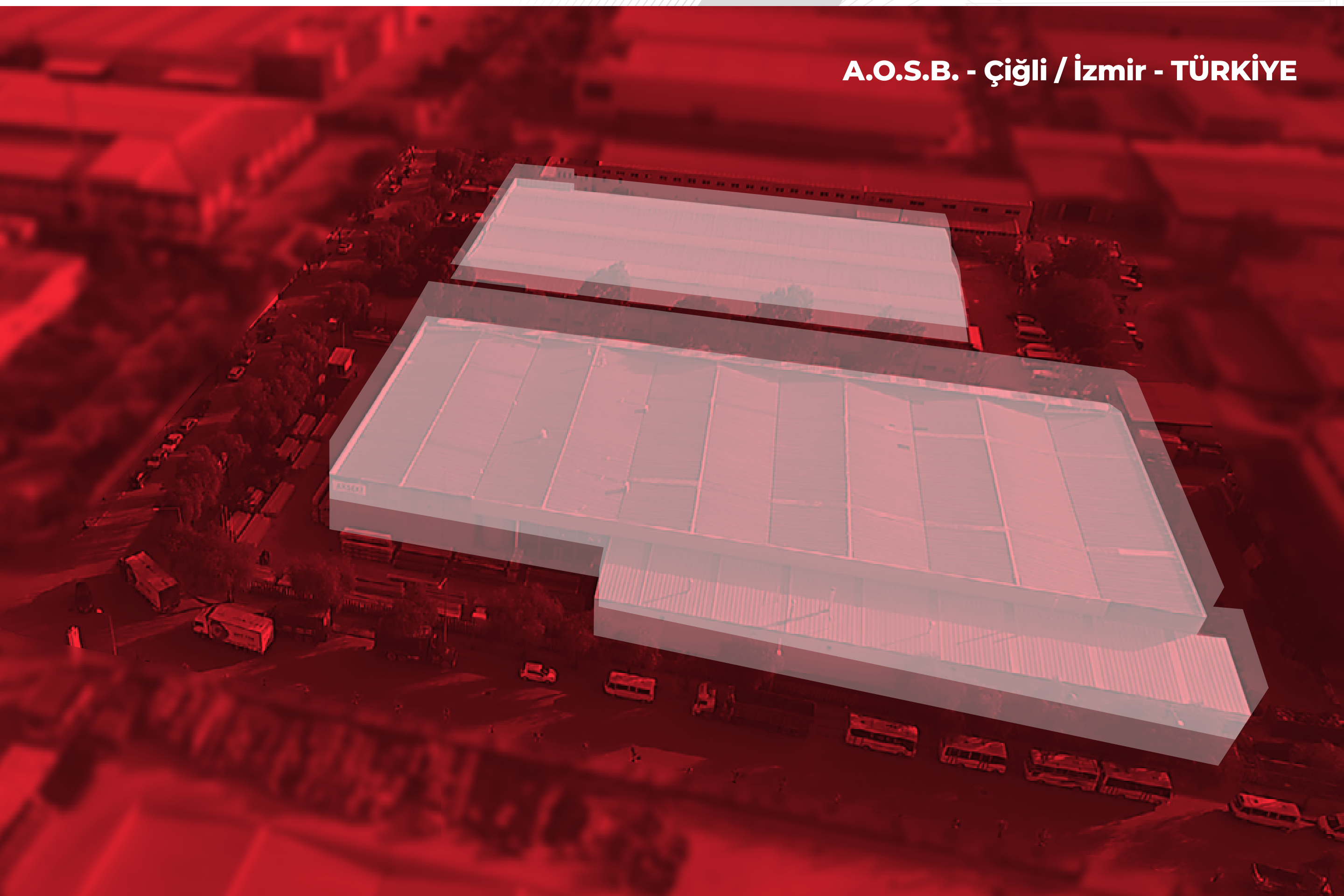

ASM40

10S

Standart Motorlar Standard Motors

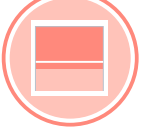

Stor Perdelerde
Roller Blinds



Panjurlarda
Shutters



Projeksiyon
Perdelerinde
Projection Screens

Boyutlar Dimensions

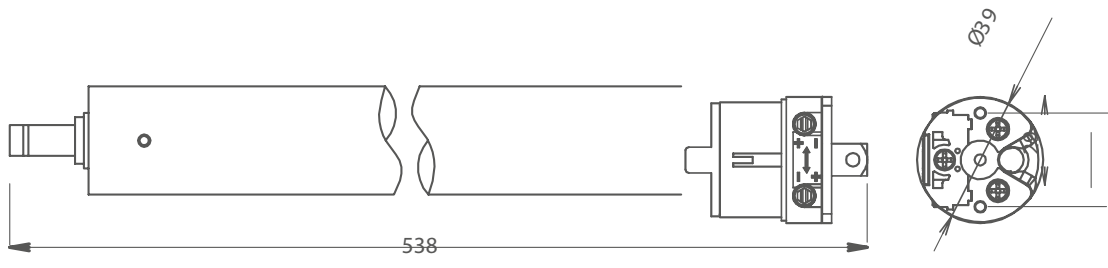

Aparatlar Components



Teknik Özellikler Technical Features

Ürün Kodu Product Code	Nominal Tork Nominal Torque	Dakika Tur Sayısı Rounds Per Min.	Tüketim Consumption	Akım Current	Çalışma Süresi Running Time	Koruma Derecesi Protection Degree	Dönüş Limiti Limit Switch Turns	Motor Uzunluğu Motor Length	Kablo Uzunluğu Cable Length
ASM.40.10S	10 Nm	14 rpm	121 W	0.53 A	4 min	IP44	29	505 mm	2 m

6
YIL/YEARS
GARANTİ
WARRANTY



ASM40

10R

Alicılı Motorlar Radio Motors



Stor Perdelerde
Roller Blinds



Panjurlarda
Shutters



Projeksiyon
Perdelerinde
Projection Screens

Boyutlar Dimensions

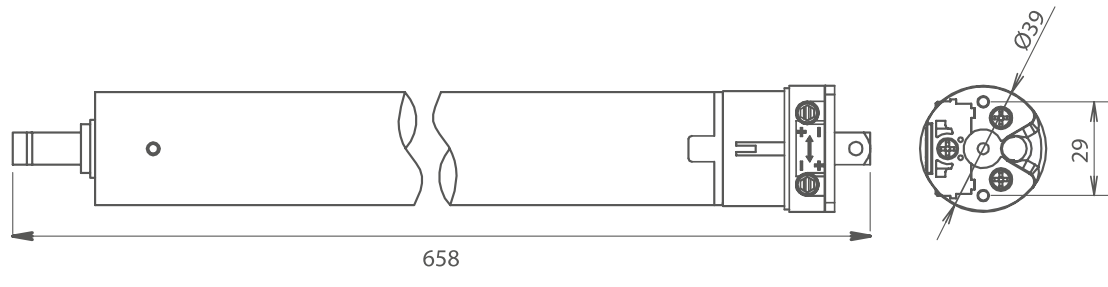

Aparatlar Components



Uzaktan Kumanda Remote Control



Teknik Özellikler Technical Features

Ürün Kodu Product Code	Nominal Tork Nominal Torque	Dakika Tur Sayısı Rounds Per Min.	Tüketim Consumption	Akım Current	Çalışma Süresi Running Time	Koruma Derecesi Protection Degree	Dönüş Limiti Limit Switch Turns	Motor Uzunluğu Motor Length	Kablo Uzunluğu Cable Length
ASM.40.10R	10 Nm	14 rpm	121 W	0.53 A	4 min	IP44	29	685 mm	2 m

6
YIL/YEARS
GARANTİ
WARRANTY



ASM60

10K - 10S - 20S
30S - 40S - 50S

Standart Motorlar Standard Motors



Güneşlik veya
Tentelerde
Sunshades or Awnings

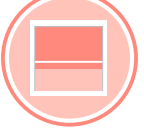

Stor Perdelerde
Roller Blinds



Panjurlarda
Shutters



Kepekli Kapılarda
Rolling Shutters

Boyutlar Dimensions

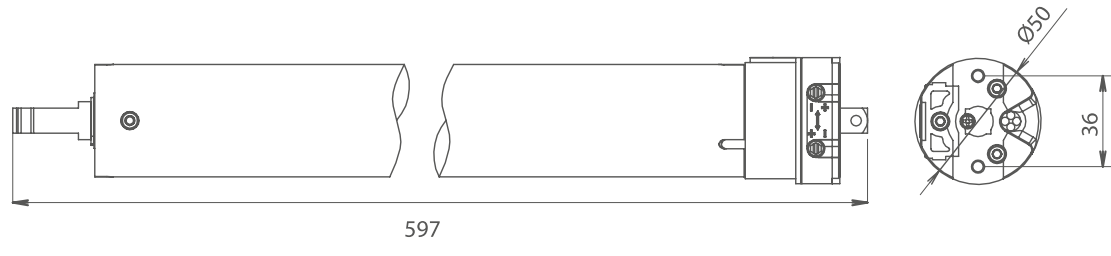

Aparatlar Components



Teknik Özellikler Technical Features

Ürün Kodu Product Code	Nominal Tork Nominal Torque	Dakika Tur Sayısı Rounds Per Min.	Tüketim Consumption	Akım Current	Çalışma Süresi Running Time	Koruma Derecesi Protection Degree	Dönüş Limiti Limit Switch Turns	Motor Uzunluğu Motor Length	Kablo Uzunluğu Cable Length
ASM.60.10K	10 Nm	17 rpm	155 W	0.68 A	4 min	IP44	14	415 mm	2 m
ASM.60.10S	10 Nm	17 rpm	155 W	0.68 A	4 min	IP44	24	460 mm	2 m
ASM.60.20S	20 Nm	17 rpm	203 W	0.84 A	4 min	IP44	24	475 mm	2 m
ASM.60.30S	30 Nm	17 rpm	226 W	0.95 A	4 min	IP44	24	500 mm	2 m
ASM.60.40S	40 Nm	13 rpm	226 W	0.95 A	4 min	IP44	24	500 mm	2 m
ASM.60.50S	50 Nm	13 rpm	224 W	1.06 A	4 min	IP44	24	500 mm	2 m

6
YIL/YEARS
GARANTİ
WARRANTY



ASM60

10RM - 20RM - 30RM
40RM - 50RM

Alicılı Motorlar Radio Motors



Güneşlik veya
Tentelerde
Sunshades or Awnings



Stor Perdelerde
Roller Blinds



Panjurlarda
Shutters



Kepekli Kapılarda
Rolling Shutters

Boyutlar Dimensions

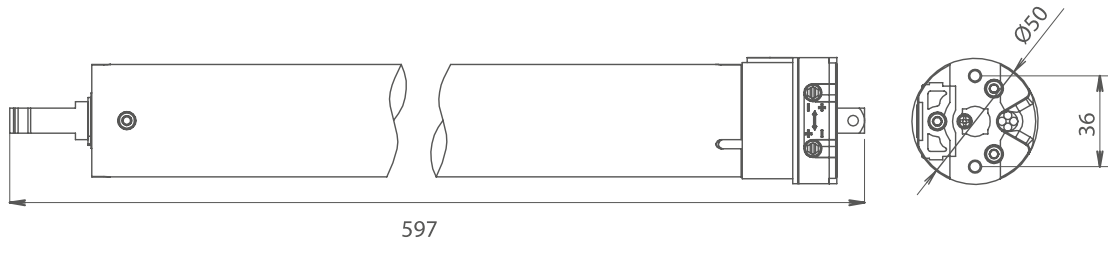

Aparatlar Components

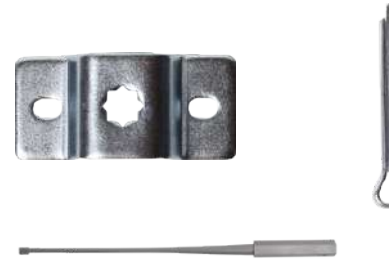

Uzaktan Kumanda Remote Control



Teknik Özellikler Technical Features

Ürün Kodu Product Code	Nominal Tork Nominal Torque	Dakika Tur Sayısı Rounds Per Min.	Tüketim Consumption	Akım Current	Çalışma Süresi Running Time	Koruma Derecesi Protection Degree	Dönüş Limiti Limit Switch Turns	Motor Uzunluğu Motor Length	Kablo Uzunluğu Cable Length
ASM.60.10RM	10 Nm	17 rpm	155 W	0.68 A	4 min	IP44	24	585 mm	2 m
ASM.60.20RM	20 Nm	17 rpm	203 W	0.84 A	4 min	IP44	24	585 mm	2 m
ASM.60.30RM	30 Nm	17 rpm	226 W	0.95 A	4 min	IP44	24	590 mm	2 m
ASM.60.40RM	40 Nm	13 rpm	226 W	0.95 A	4 min	IP44	24	590 mm	2 m
ASM.60.50RM	50 Nm	13 rpm	244 W	1.06 A	4 min	IP44	24	590 mm	2 m

6
YIL/YEARS
GARANTİ
WARRANTY



ASM60

30M - 50M
50MB

Redüktörlü Motorlar Manual Override Motors



Güneşlik veya
Tentelerde
Sunshades or Awnings



Stor Perdelerde
Roller Blinds



Panjurlarda
Shutters



Kepenli Kapılarda
Rolling Shutters

Boyutlar Dimensions

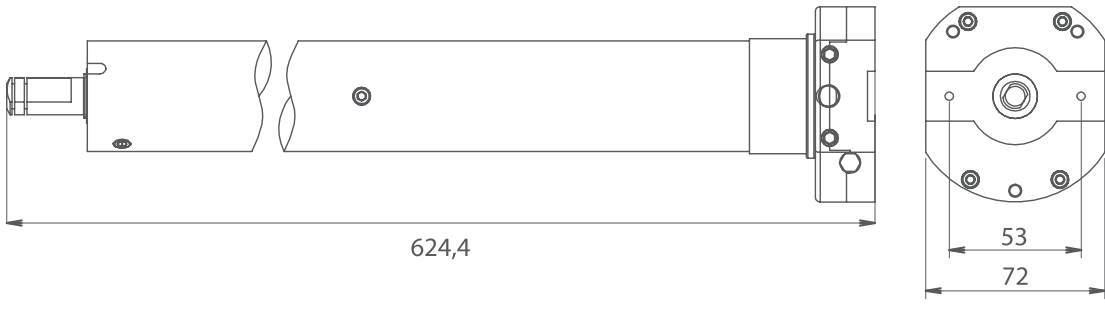

Aparatlar Components



Teknik Özellikler Technical Features

Ürün Kodu Product Code	Nominal Tork Nominal Torque	Dakika Tur Sayısı Rounds Per Min.	Tüketim Consumption	Akım Current	Çalışma Süresi Running Time	Koruma Derecesi Protection Degree	Dönüş Limiti Limit Switch Turns	Motor Uzunluğu Motor Length	Kablo Uzunluğu Cable Length
ASM.60.30M	30 Nm	15 rpm	235 W	1.03 A	4 min	IP44	15	645 mm	2 m
ASM.60.50M	50 Nm	12 rpm	282 W	1.23 A	4 min	IP44	15	645 mm	2 m
ASM.60.50MB	50 Nm	12 rpm	282 W	1.23 A	4 min	IP44	15	645 mm	2 m

Not: 60'lık motoru 70'lik boruya çevirir.

6
YIL/YEARS
GARANTİ
WARRANTY

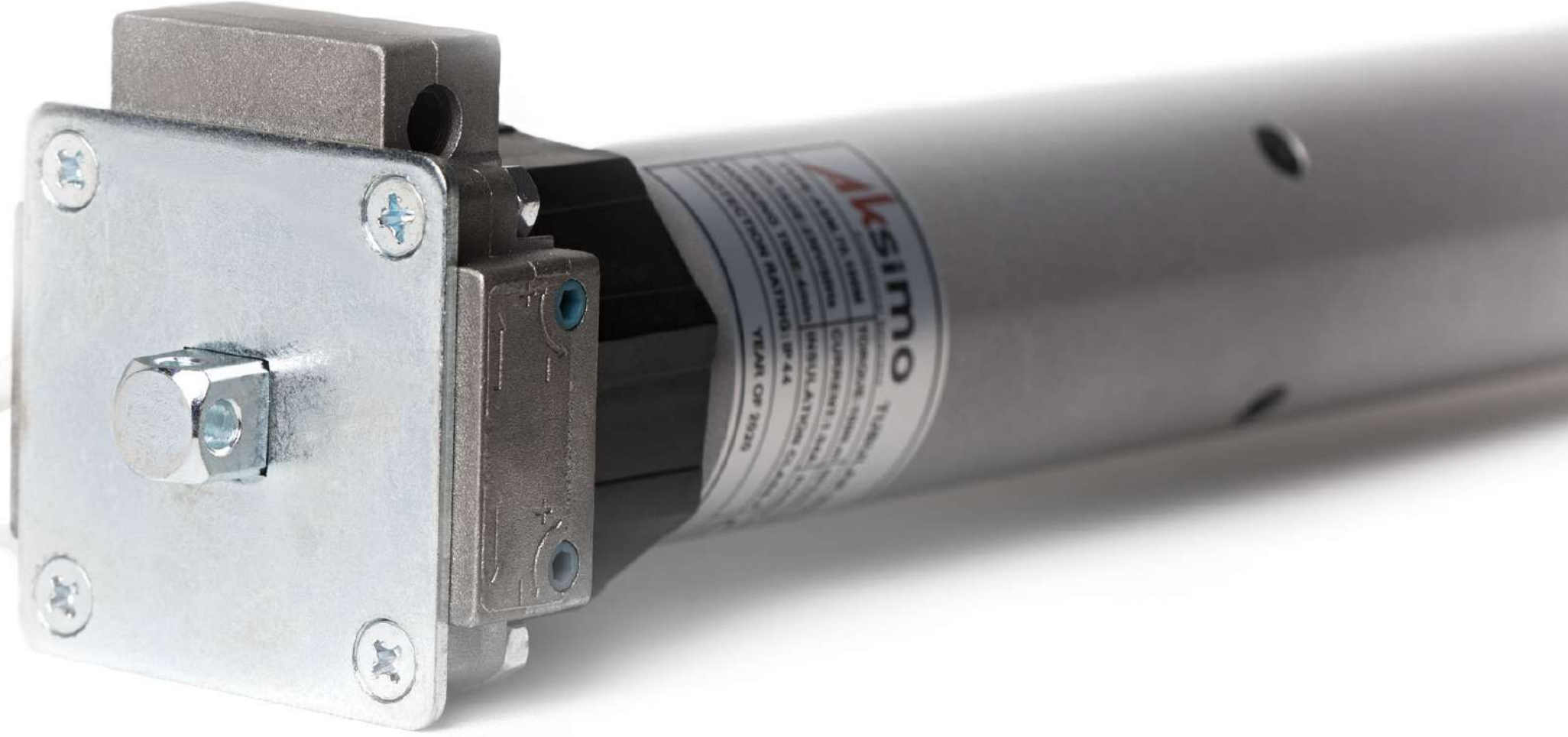

ASM70

60S - 80S - 100S
140S - 180S

Standart Motorlar Standard Motors

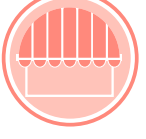

Güneşlik veya
Tentelerde
Sunshades or
Awnings



Kepekli Kapılarda
Rolling Shutters



Garaj Kapılarında
Garage Doors

Boyutlar Dimensions

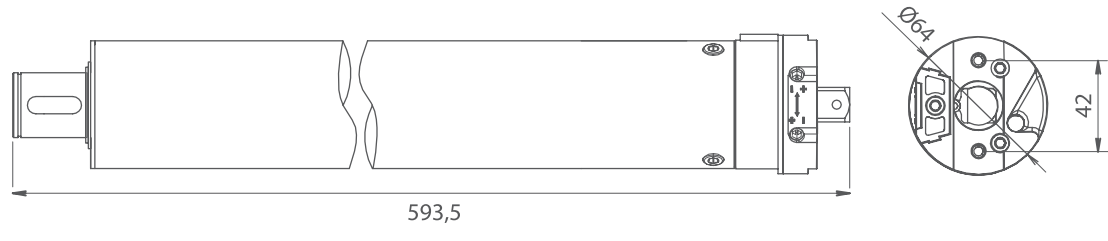

Aparatlar Components



Teknik Özellikler Technical Features

Ürün Kodu Product Code	Nominal Tork Nominal Torque	Dakika Tur Sayısı Rounds Per Min.	Tüketim Consumption	Akım Current	Çalışma Süresi Running Time	Koruma Derecesi Protection Degree	Dönüş Limiti Limit Switch Turns	Motor Uzunluğu Motor Length	Kablo Uzunluğu Cable Length
ASM.70.60S	60 Nm	12 rpm	288 W	1.28 A	4 min	IP44	33	680 mm	2 m
ASM.70.80S	80 Nm	12 rpm	350 W	1.50 A	4 min	IP44	33	680 mm	2 m
ASM.70.100S	100 Nm	12 rpm	441 W	1.94 A	4 min	IP44	33	680 mm	2 m
ASM.70.140S	140 Nm	9 rpm	465 W	2.02 A	4 min	IP44	33	680 mm	2 m
ASM.70.180S	180 Nm	9 rpm	530 W	2.45 A	4 min	IP44	33	685 mm	2 m

6
YIL/YEARS
GARANTİ
WARRANTY



ASM70

100RM - 120RM
140RM - 180RM

Alicılı Motorlar Radio Motors



Güneşlik veya
Tentelerde
Sunshades or
Awnings



Kepekli Kapılarda
Rolling Shutters



Garaj Kapılarında
Garage Doors

Boyutlar Dimensions

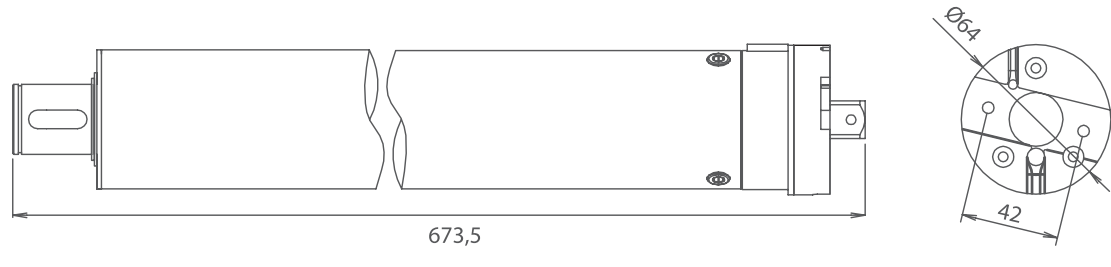

Aparatlar Components

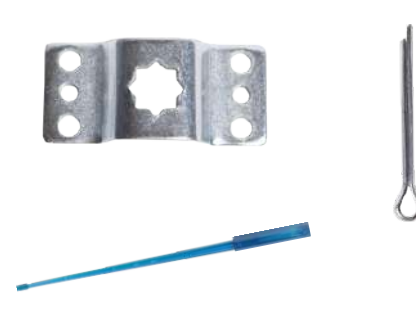

Uzaktan Kumanda Remote Control



Teknik Özellikler Technical Features

Ürün Kodu Product Code	Nominal Tork Nominal Torque	Dakika Tur Sayısı Rounds Per Min.	Tüketim Consumption	Akım Current	Çalışma Süresi Running Time	Koruma Derecesi Protection Degree	Dönüş Limiti Limit Switch Turns	Motor Uzunluğu Motor Length	Kablo Uzunluğu Cable Length
ASM.70.100RM	100 Nm	12 rpm	410 W	1.79 A	4 min	IP44	20	705 mm	2 m
ASM.70.120RM	120 Nm	9 rpm	410 W	1.79 A	4 min	IP44	20	705 mm	2 m
ASM.70.140RM	140 Nm	9 rpm	410 W	1.79 A	4 min	IP44	20	705 mm	2 m
ASM.70.180RM	180 Nm	9 rpm	530 W	2.45 A	4 min	IP44	33	845 mm	2 m

6
YIL/YEARS
GARANTİ
WARRANTY



ASM70

60M - 80M - 100M - 120M
140M - 120MB - 190MB

Redüktörlü Motorlar Manual Override Motors



Tentelerde
Awnings



Kepenli Kapılarda
Rolling Shutters



Garaj Kapılarında
Garage Doors

Boyutlar Dimensions

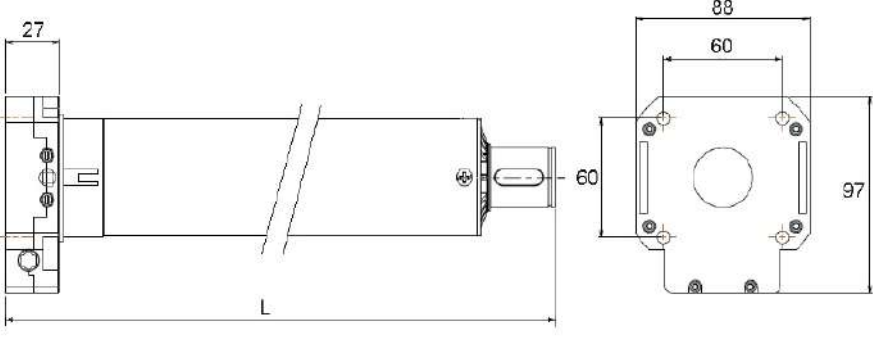

Aparatlar Components



Teknik Özellikler Technical Features

Ürün Kodu Product Code	Nominal Tork Nominal Torque	Dakika Tur Sayısı Rounds Per Min.	Tüketim Consumption	Akım Current	Çalışma Süresi Running Time	Koruma Derecesi Protection Degree	Dönüş Limiti Limit Switch Turns	Motor Uzunluğu Motor Length	Kablo Uzunluğu Cable Length
ASM.70.60M	60 Nm	12 rpm	288 W	1.28 A	4 min	IP44	28	690 mm	2 m
ASM.70.80M	80 Nm	12 rpm	350 W	1.50 A	4 min	IP44	28	690 mm	2 m
ASM.70.100M	100 Nm	12 rpm	441 W	1.94 A	4 min	IP44	28	690 mm	2 m
ASM.70.120M	120 Nm	12 rpm	450 W	2.00 A	4 min	IP44	28	690 mm	2 m
ASM.70.140M	140 Nm	9 rpm	465 W	2.02 A	4 min	IP44	28	690 mm	2 m
ASM.70.120MB	120 Nm	12 rpm	450 W	2.00 A	4 min	IP44	28	690 mm	2 m
ASM.70.140MB	140 Nm	9 rpm	465 W	2.02 A	4 min	IP44	28	690 mm	2 m
ASM.70.190MB	190 Nm	9 rpm	540 W	2.60 A	4 min	IP44	28	760 mm	2 m

Not: 70'lik motorlu olan MB'ler
102'lik adaptörlüdür.

6
YIL/YEARS
GARANTİ
WARRANTY

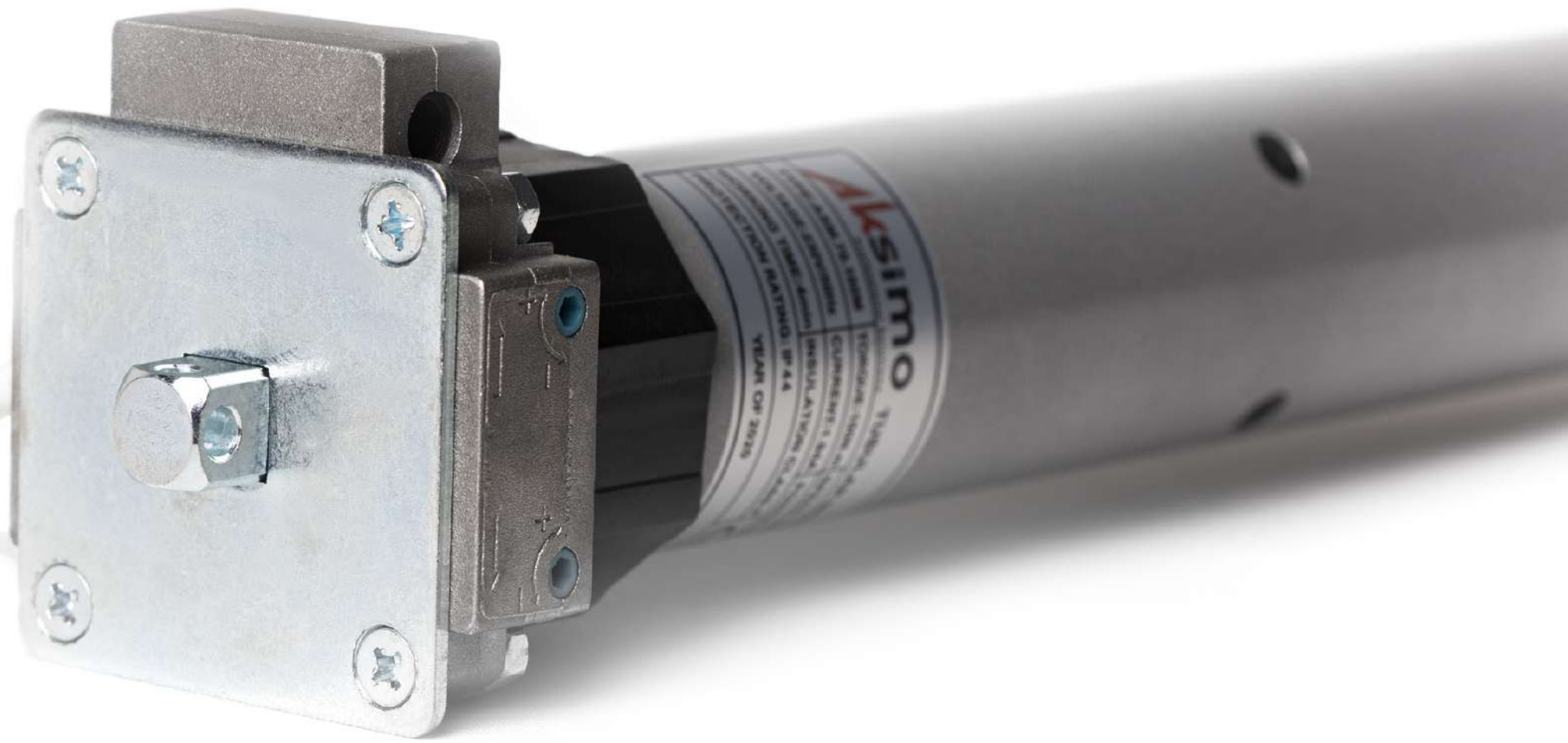

ASM102

230S - 330S

Standart Motorlar Standard Motors



Kepenli Kapılarda
Rolling Shutters

Boyutlar Dimensions

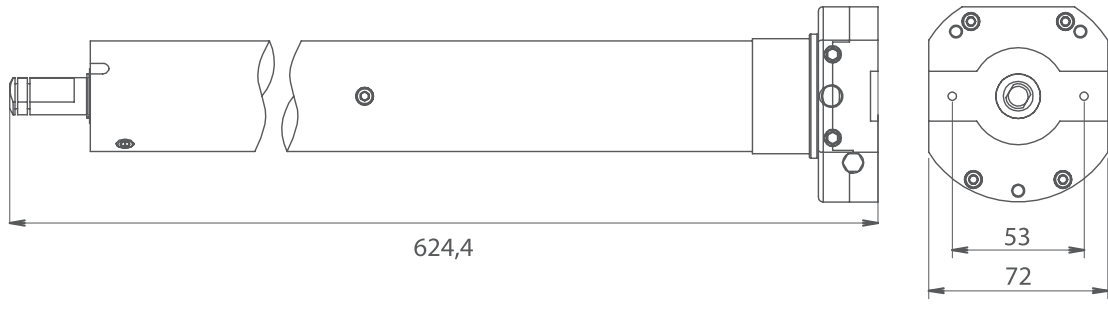

Aparatlar Components



Teknik Özellikler Technical Features

Ürün Kodu Product Code	Nominal Tork Nominal Torque	Dakika Tur Sayısı Rounds Per Min.	Tüketim Consumption	Akım Current	Çalışma Süresi Running Time	Koruma Derecesi Protection Degree	Dönüş Limiti Limit Switch Turns	Motor Uzunluğu Motor Length	Kablo Uzunluğu Cable Length
ASM.102.230S	230 Nm	12 rpm	830 W	2.80 A	4 min	IP44	13	620 mm	2 m
ASM.102.330S	330 Nm	6 rpm	950 W	4.20 A	4 min	IP44	13	655 mm	2 m

6
YIL/YEARS
GARANTİ
WARRANTY

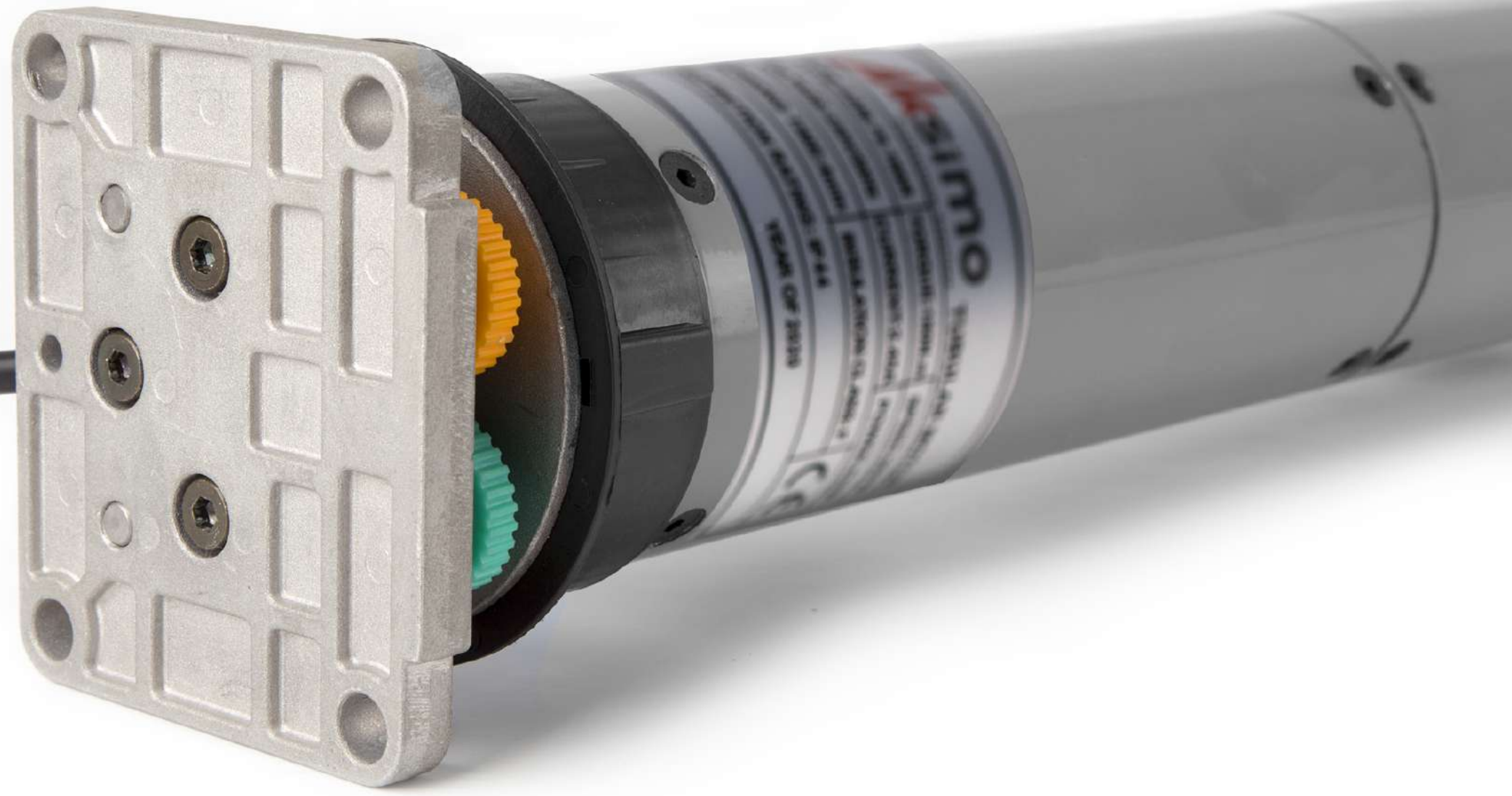

ASM102

230M - 300M
330M

Redüktörlü Motorlar Manual Override Motors



Kepenli Kapılarda
Rolling Shutters

Boyutlar Dimensions

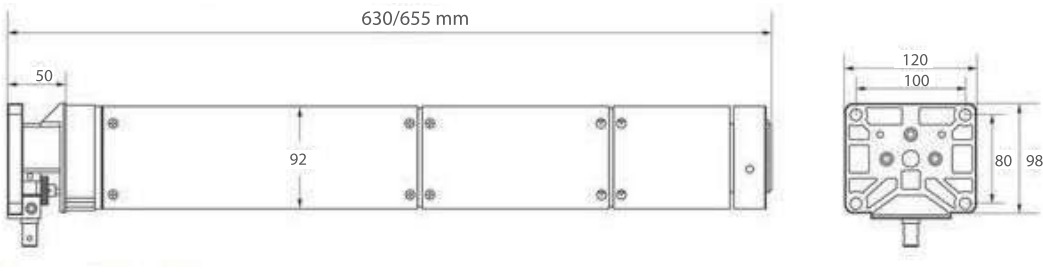

Aparatlar Components



Teknik Özellikler Technical Features

Ürün Kodu Product Code	Nominal Tork Nominal Torque	Dakika Tur Sayısı Rounds Per Min.	Tüketim Consumption	Akım Current	Çalışma Süresi Running Time	Koruma Derecesi Protection Degree	Dönüş Limiti Limit Switch Turns	Motor Uzunluğu Motor Length	Kablo Uzunluğu Cable Length
ASM.102.230M	230 Nm	12 rpm	830 W	2.80 A	4 min	IP44	13	635 mm	2 m
ASM.102.300M	300 Nm	8 rpm	920 W	4.00 A	4 min	IP44	13	670 mm	2 m
ASM.102.330M	330 Nm	6 rpm	950 W	4.20 A	4 min	IP44	13	670 mm	2 m

6
YIL/YEARS
GARANTİ
WARRANTY

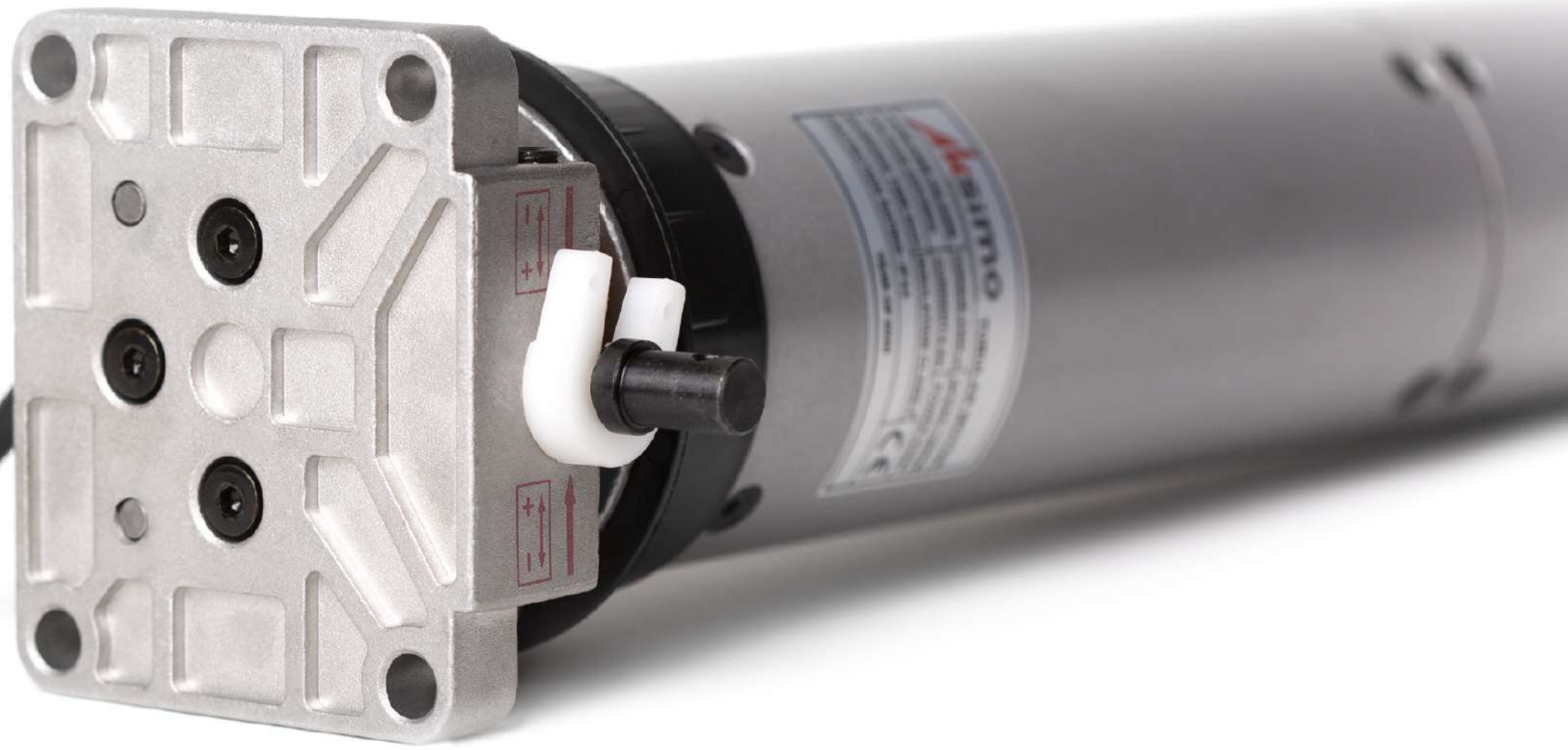



Kumandalar, Alicilar ve Butonlar

Remotes, Receives and Buttons

Uzaktan Kumanda
Remote Control

1 Kanallı / 1 Channel



Ürün No / Prod. No: **ASM.OTM.KMD.201**

Uzaktan Kumanda
Remote Control

5 Kanallı / 5 Channel



Ürün No / Prod. No: **ASM.OTM.KMD.202**

Uzaktan Kumanda
Remote Control

16 Kanallı / 16 Channel



Ürün No / Prod. No: **ASM.OTM.KMD.203**

Alıcı
Receiver



Ürün No / Prod. No: **ASM.OTM.ALC.101**

Uzaktan Kumanda
Remote Control

1 Kanallı / 1 Channel



Ürün No / Prod. No: **ASM.OTM.KMD.401**

Uzaktan Kumanda
Remote Control

3 Kanallı / 3 Channel



Ürün No / Prod. No: **ASM.OTM.KMD.402**

Uzaktan Kumanda
Remote Control

1 Kanallı / 1 Channel



Ürün No / Prod. No: **ASM.OTM.KMD.251**

Alici
Receiver

**1 Kanallı
1 Channel**



Ürün No / Prod. No:
ASM.OTM.ALC.331

Alici
Receiver

**4 Kanallı
4 Channel**



Ürün No / Prod. No:
ASM.OTM.ALC.334

Uzaktan Kumanda
Remote Control

**2 Kanallı
2 Channel**



Ürün No / Prod. No:
ASM.OTM.KMD.431

Uzaktan Kumanda
Remote Control

**4 Kanallı
4 Channel**



Ürün No / Prod. No:
ASM.OTM.KMD.434

Sıva Altı
Flush Mounted

Buton / Button



Ürün No / Prod. No: **AKS.BUT.00.SA**

Sıva Üstü
Flash Mounted

Buton / Button



Ürün No / Prod. No: **AKS.BUT.00.SU**

Anahtar Tip Uzaktan Kumanda
Remote Control

2 Kanallı / 2 Channels



Ürün No / Prod. No: **ASM.OTM.KMD.411**

WS 311, WS 316, WS 317, WS 318, WS 100GK, WS 150GK Alicılar ile uyumludur
Compatible with WS 311, WS 316, WS 317, WS 318, WS 100GK, WS 150GK receivers

Anahtar Tip Uzaktan Kumanda
Remote Control

4 Kanallı / 4 Channel



Ürün No / Prod. No: **ASM.OTM.KMD.412**

Power Alıcı
Power Receiver

2 Kanallı / 2 Channel



Ürün No / Prod. No: **ASM.OTM.ALC.321**

Power Alıcı
Power Receiver

4 Kanallı / 4 Channels



Ürün No / Prod. No: **ASM.OTM.ALC.324**

Buton Bağlantılı
Button Connected

Kepek Alıcısı / Rolling Receiver



Ürün No / Prod. No: **ASM.OTM.ALC.311**

Zincirli Motor
Chain Engine

Alıcı / Receiver



Ürün No / Prod. No: **ASM.OTM.ALC.317**

Tüp Motor
Tubular Engine

Alıcı / Receiver



Ürün No / Prod. No: **ASM.OTM.ALC.316**

WS 311, WS 316, WS 317, WS 318, WS 100GK, WS 150GK Alıcılar ile uyumludur
Compatible with WS 311, WS 316, WS 317, WS 318, WS 100GK, WS 150GK receivers

Zincirli Motor Uyumlu
Chain Engine Compatible

Alıcı / Receiver



Ürün No / Prod. No: **ASM.OTM.ALC.318**

Zincirli Motor
Chain Motor

Alıcı / Receiver



Ürün No / Prod. No: **ASM.OTM.ALC.340**

Güç Kaynağı
Power Supply

1100 W / 1 Channel



Ürün No / Prod. No: **ASM.OTM.110.GK**

Güç Kaynağı
Power Supply

1500 W



Ürün No / Prod. No: **ASM.OTM.150.GK**

Fotosel Gözü
Rolling Receiver



Ürün No / Prod. No: **ASM.OTM.EFT.001**

AKSEKI[®]

Aksimo
Professional Solutions

Eskiizmir Cad. No:389 Bozyaka
Karabağlar İzmir / Turkey

TEL: 0232 271 54 22 (PBX)
FAX: 0232 271 39 05

aksekiyapi.com.tr | info@aksekiyapi.com



aksekiyapi



aksekiyapi